

S 30

Granulators

Mod. S30-50

Caratteristiche tecniche

- Realizzati per applicazioni bordopressa (iniezione, soffiaggio ed estrusione) e per usi generali.
- Un modello disponibile in più di 20 versioni.
- Motore e quadro elettrico IP55.
- Apertura rapida e facilità di pulizia.
- Grande cassetto di raccolta del macinato, a tenuta.
- Completamente insonorizzati per una bassa rumorosità di esercizio.
- Sicurezze conformi alle normative CE.
- Vari sistemi di alimentazione e scarico, sono disponibili, come optional, per ogni esigenza del cliente.
- Taglio a "doppia inclinazione", per ridurre il consumo di energia e la formazione di calore e polvere.



Technical data

- Designed for beside the press operation (injection, blow moulding and extrusion) and general purpose operation.
- One model, over 20 versions available.
- IP55 control cabinet and electric motor.
- Quick opening and easy cleaning.
- Fully sound enclosed for low operating noise level.
- Safety complies with CE standards.
- A range of feed and discharge options are available to meet each customers requirements.
- Advanced "Scissor" cutting action, reduces energy consumption, heat and dust generation.

applications



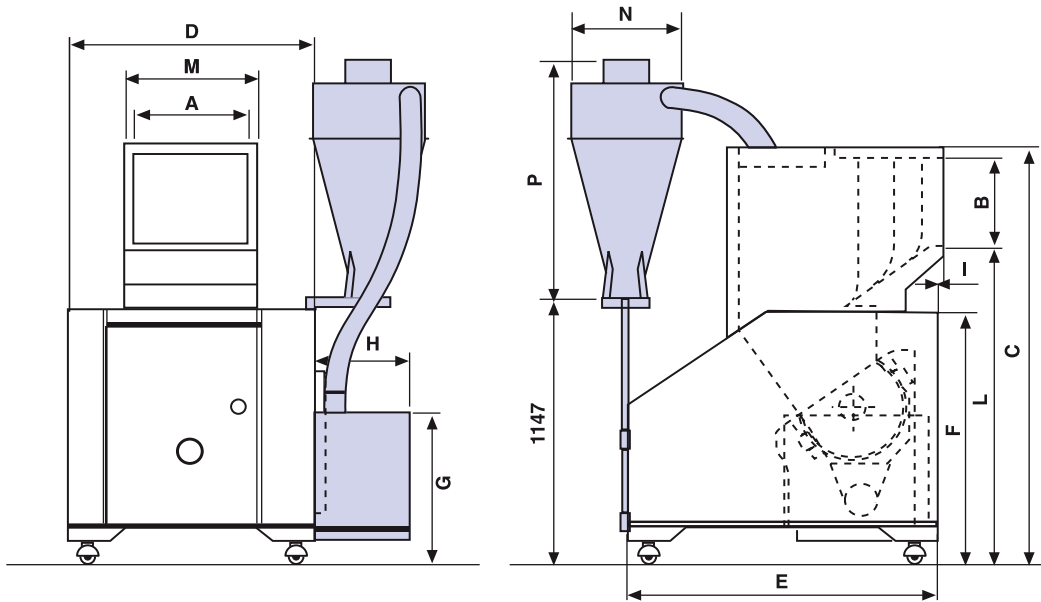







■ OPTIONAL

	A	B	C	D	E	F	G	H	I	L	N	P
S30-50	510	305	1702	1019	1102	1034	522	450	15	1350	420	900



	 mm	 n°	 n°	 mm	 RPM	 Ø mm	 Kg/H
S30-50	305x510	3	2	305	460	8	250-340



www.cmg.it